



SPECIFICATION

Supply Voltage:	48V DC to Track-Pipe [®] connector
Primary Material:	Aluminium
Finish:	Stone Rumbled™ Aluminium, Black
Weight:	0.7kg
Mounting:	Track-Pipe [®] hook
IP Rating:	IP20
CRI:	90 CRI
Luminous Flux:	0-1650 lm / 2700K 0-1750 lm / 3000K 0-1875 lm / 3500K (by request) 0-1935 lm / 4000K
Luminaire Efficacy:	up to 101 lm/W
Current (mA max.):	350 mA
Power Consumption (max. typ.):	14.5 W
Colour Temperature:	2700K, 3000K, 3500K (by request), 4000K
Colour Consistency:	≤ 1x2 MacAdam Ellipses
Colour Stability:	<0.003 Δu',v' 50,000 hrs
Lumen Maintenance:	50,000 hrs L70/B0/FO
Optics / Beam Angles:	21°, 38°, 59°, Spreader (22°x63°), Wall Wash
Accessories:	Honeycomb Louvre
Operating Temp:	Ambient -20°C/+25°C
Control:	switched, DALI
Standard / Certification:	CE UKCA [BS EN 60598] Manufactured in line with UL2108
Manufacture:	UK

PRODUCT DESCRIPTION

Ninety-Nine is a simple, modernist spotlight made from heavy-gauge, extruded aluminium. Configurable high-performance light engine with comprehensive BIM and photometry data. Available in VOC free Eco paint finishes, black anodised or Stone Rumbled for maximum Circular Economy. (Swivel component stone rumbled on painted finishes.) Made in the UK and tested to BS EN 60598 | CE | UKCA.

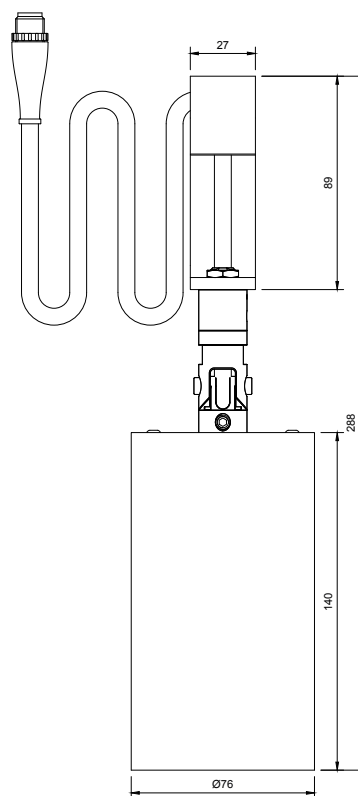

SPECIFICATION / PRODUCT CODE

EXAMPLE: NMS-SR-TP-2700-DA-21-HL

FINISH Stone Rumbled [SR] Black [BL]	MOUNTING Track-Pipe [TP]	CCT 2700K [2700] 3000K [3000] 3500K [3500] 4000K [4000]	CONTROL Switched [SW] DALI [DA]	BEAM ANGLE 21° [21] 38° [38] 59° [59] Spreader Lens [SL] Wall Wash [WW]	ACCESSORIES No Accessories [NA] Honeycomb Louvre [HL]
---	------------------------------------	--	--	---	--

MOUNTINGS



TRACK-PIPE®

For fixing to low voltage Track-Pipe® systems.

Finish:	Stone Rumbled™ Black
Material:	Aluminium
Voltage Type:	DC
IP Rating:	IP20
Certification:	CE / UKCA

