

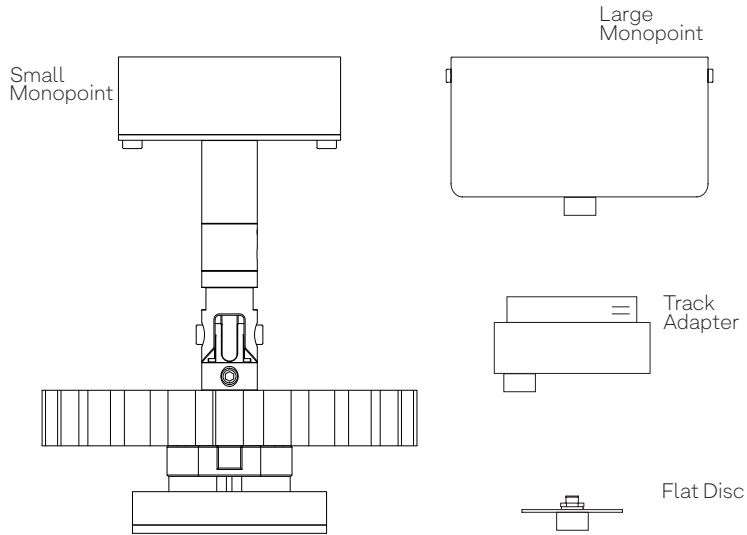

## SKIN+BONES™ SPOTLIGHT



## YOUR PRODUCT

Thank you for purchasing this FACTORYLUX product. It has been designed and hand-built in the UK to give you many years of reliable service. Please read these user instructions carefully.

## WARNING

- **Shut off power before installation, adjusting or handling! Failure to do so may result in irreversible damage to the LED module and failure of the luminaire**
- Light fitting to be installed by a competent person, in accordance with all national and local building codes or with current wiring and building regs
- Bathroom installation by authorised contractor only
- Always use fixings appropriate to the mounting location
- IP20 unless otherwise stated on product labelling
- Driver/PSU must not be thermally insulated
- Maximum ambient temperature 25°C
- Must be installed out of arms reach

## TROUBLESHOOTING

In the event of failure, fault or damage, shut off power and contact our technical department via [FACTORYLUX.com](http://FACTORYLUX.com).

The light source contained in this luminaire shall only be replaced by the manufacturer, their service agent or a similar qualified person.

## STAY UP TO DATE

For up to date design and product information visit [FACTORYLUX.com](http://FACTORYLUX.com)  
You can also contact us via instant support or email [hello@factorylux.com](mailto:hello@factorylux.com)

## SKIN+BONES SPOTLIGHT | WHAT'S INCLUDED



3mm hex key

Designed, made & tested in the UK  
1.INS.SKIN+BONES-SPOTLIGHT.2306  
© Factorylux



Factorylux | Greenhill Mills | Hebden Bridge | HX7 5QF | UK **FACTORYLUX**

## LARGE MONOPOINT | WHAT'S INCLUDED

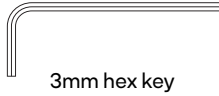

3mm hex key

## LARGE MONOPOINT | TOOLS REQUIRED

- 3mm hex key

## LARGE MONOPOINT | INSTALLATION DIAGRAM

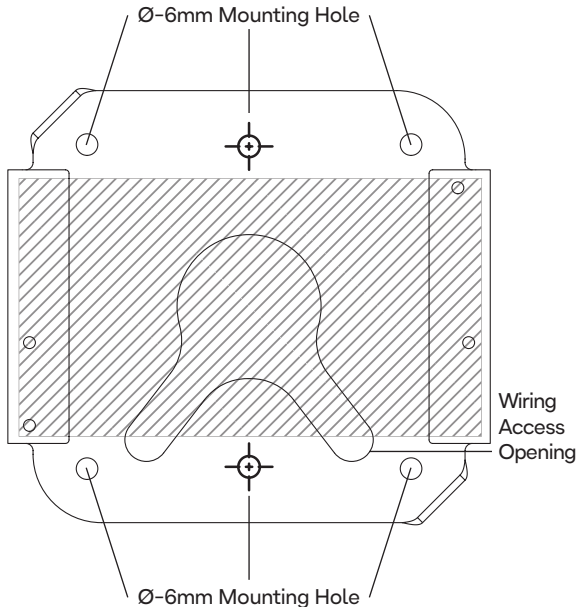

## LARGE MONOPOINT | INSTALLATION

Luminaire with professional specification integral LED. This product is intended for use with an LED driver fitted in the Ceiling Enclosure, with the luminaire wiring pre installed.

**WARNING:** Light fitting to be insulated and grounded in accordance with local and national building code and/or wiring regulations. **Shut off power before installation. For use in dry locations only.**

**WARNING:** Ensure no wires become trapped when fixing lid in place.

1. Using 3mm hex key provided, remove mounting screws from the large monopoint, and separate large monopoint lid from base
2. Lid will remain attached by the LED wiring. Ensure no strain is placed on LED wiring during installation process
3. Drill holes and insert plugs if the surface requires it, using mounting holes as a template.
4. Fix monopoint base to mounting surface using appropriate fixings
5. Connect branch supply wiring to the luminaire wiring. Connect control system wiring (if present). Refer to WIRING DIAGRAM for specific wiring requirements of the luminaire.
6. If adjusting luminaire, see ADJUSTING section
7. Carefully place large monopoint lid over the base, aligning the fixing holes
8. Using the 3mm hex key provided, and the mounting screws removed in part 1, fix large monopoint lid in place. Do not over-tighten

Designed, made & tested in the UK  
1.LINS.LARGE-MONOPOINT.2306  
© Factorylux



## SMALL MONOPOINT | WHAT'S INCLUDED



3mm hex key

## SMALL MONOPOINT | INSTALLATION DIAGRAM

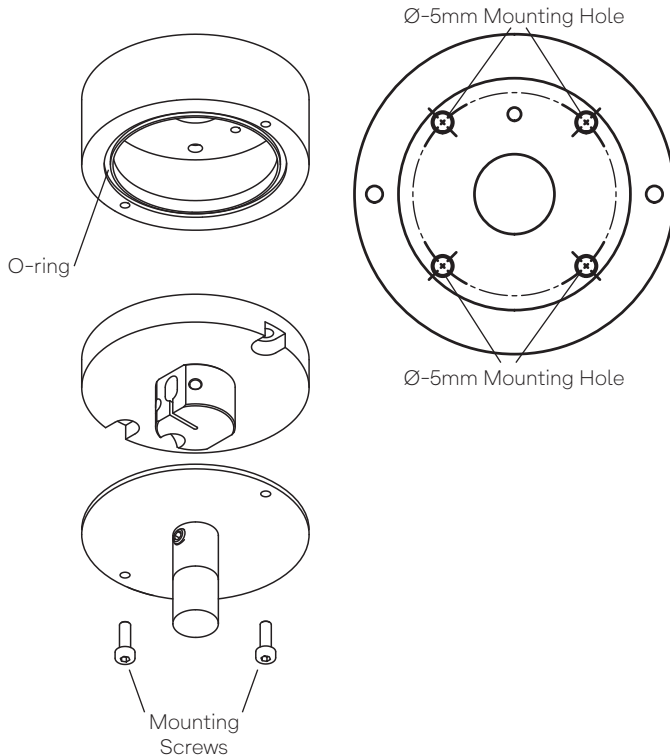

## SMALL MONOPOINT | INSTALLATION

Luminaire with professional specification LED. LED driver / PSU (if supplied) to be mounted in a dry location.

**WARNING:** Light fitting to be insulated and grounded in accordance with local and national building code and/or wiring regulations.

**Shut off power before installation.**

**Ensure no wiring becomes trapped during installation.**

**Consider the orientation of installation when mounting on non-horizontal surfaces. Surfaces of greater than 15 degree pitch may not be suitable.**

1. Using 3mm hex key provided, remove mounting screws from the small monopoint, and separate small monopoint cover from base
2. Cover will remain attached by the LED wiring. Ensure no strain is placed on LED wiring during installation process
3. Drill holes and insert plugs if the surface requires it, using mounting holes as a template
4. Fix monopoint base to mounting surface using appropriate fixings
5. Relocate rubber o-ring between cover and monopoint base (if provided)
6. Reattach cover to small monopoint using mounting screws
7. To attach the driver or PSU, refer to ADJUSTING section.

Designed, made & tested in the UK  
1.LINS.SMALL-MONOPOINT.2206  
© Factorylux



## DISC MONOPOINT | INSTALLATION DIAGRAM

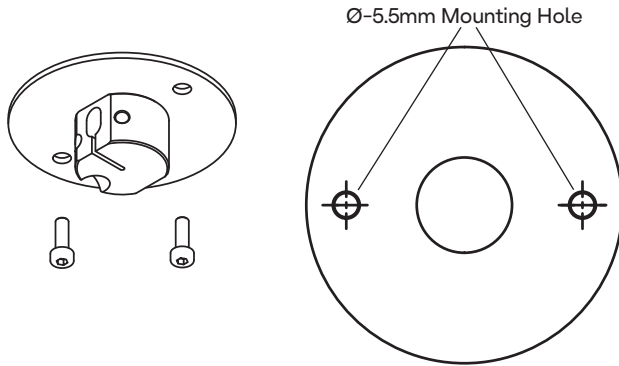

## DISC MONOPOINT | INSTALLATION

Luminaire with professional specification LED. LED driver / PSU (if supplied) to be mounted in a dry location.

**WARNING:** Light fitting to be insulated and grounded in accordance with local and national building code and/or wiring regulations. Shut off power before installation.

**WARNING:** Ensure no wires become trapped when fixing lid in place.

**NOTE:** Ensure clearance hole of at least 33mm in mounting surface at centre of disc.

1. Disc will remain attached by the LED wiring. Ensure no strain is placed on LED wiring during installation process.

### FOR INSTALLATION TO TERMINAL BOX

1. Use appropriate screws to fix disc to pre installed terminal box
2. For attaching the driver or PSU, refer to ADJUSTING section

### FOR INSTALLATION TO FLAT SURFACE

1. Drill holes and insert plugs if the surface requires it, using mounting holes as a template
2. Fix disc to mounting surface using appropriate fixings
3. For attaching the driver or PSU, refer to ADJUSTING section.

Designed, made & tested in the UK  
1\_INS\_DISC-MONOPOINT\_2308  
© Factorylux



## TRACK ADAPTER | INSTALLATION DIAGRAM

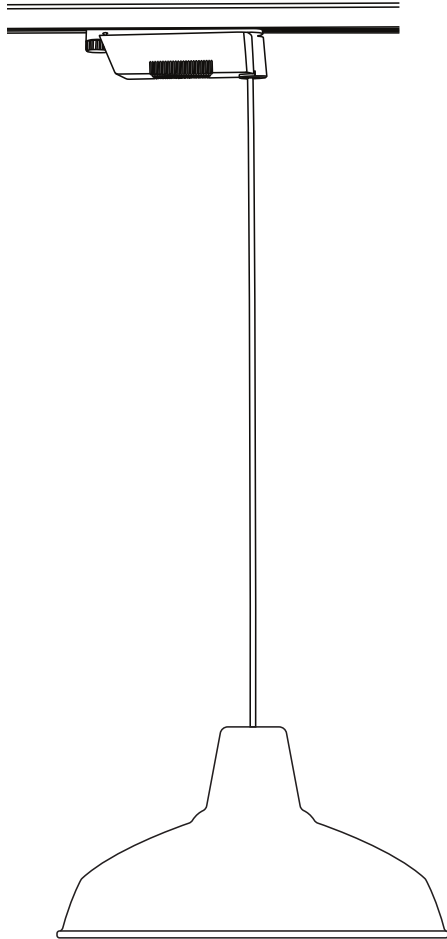

## TRACK ADAPTER | INSTALLATION

**WARNING:** Light fitting to be insulated and grounded in accordance with local and national building code and/or wiring regulations. **Shut off power before installation. For use in dry locations only.**

- We have assembled this luminaire with the chosen track adapter. Please follow the track manufacturers instructions for installation
- Check compatibility between the Track Adapter and the track before installation commences.
- Ensure mechanical locking mechanism on Track Adapter is fully engaged in track
- Do not support any weight other than supplied luminaire from Track Adapter

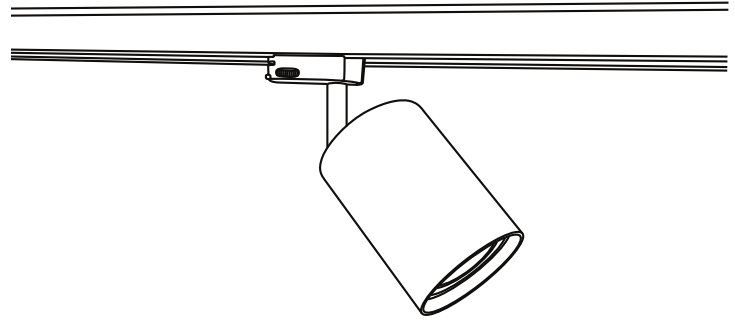

Designed, made & tested in the UK  
LINS\_TRACK-ADAPTER\_2306  
© Factorylux



Factorylux | Greenhill Mills | Hebden Bridge | HX7 5QF | UK FACTORYLUX®

## ADJUSTING DRIVER/PSU

**WARNING:** Shut off power and allow to cool.

**NOTE:** For remotely installed drivers, the cable length can be shortened, but not lengthened. Always ensure the weight of the luminaire is fully supported when making adjustments. Do not remove product labels.

1. Release LED wiring from driver by depressing Wire Release Button with a small blunt object.

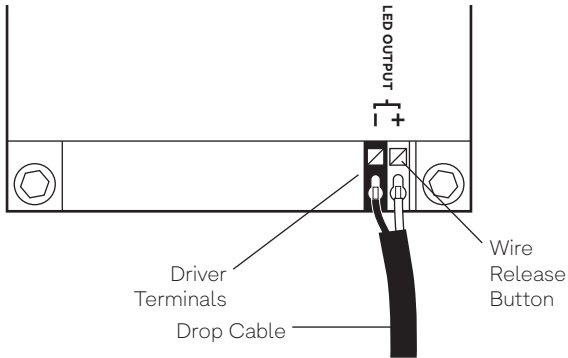

2. For large monopoint, cut the cable 150mm from the inside of the ceiling enclosure lid. For other mountings, cut to relevant length for your installation. Loosen the cord grip grub screw and move the mounting/lid out of the way.



3. Strip cable outer sheath by 15mm, then strip the black and red inner wires by 9mm to expose conductors. Twist each conductor wire using fingers
4. Push black wire into black NEGATIVE “-” terminal of LED OUTPUT 1. Push red wire into red or grey POSITIVE “+” terminal of LED OUTPUT 1

## HANDLING & CLEANING

**WARNING:** Shut off power and allow to cool.

- Wipe gently with a dry, soft cloth
- Clean gloves to be worn when handling stone rumbled finish
- Cleaning products, scratching, abrasion, damp, oils, liquids etc may have a detrimental effect.

## ADJUSTING (LUMINAIRE)

**WARNING** Shut off power and allow to cool.

**NOTE:** Do not remove batch code label.

### NINETY-NINE™

- Luminaire can be adjusted 360° on the vertical axis by securely holding and twisting by hand.
- Luminaire can be adjusted 90° on the horizontal axis by loosening the adjustable elbow joint screws using the provided 3mm hex key, rotating to desired location, and re-tightening both screws with the hex key.

### SKIN+BONES™ SPOTLIGHT

- Luminaire can be adjusted 360° on the vertical axis by securely holding and twisting by hand.
- Luminaire can be adjusted 90° on the horizontal axis by loosening the adjustable elbow joint screws using the provided 3mm hex key, rotating to desired location, and re-tightening both screws with the hex key.

Designed, made & tested in the UK  
1.LINS\_ADJUSTING.2308  
© Factorylux



Factorylux | Greenhill Mills | Hebden Bridge | HX7 5QF | UK FACTORYLUX

WIRING DIAGRAM: 100-250V~AC  
1-10V, DALI OR SWITCHED

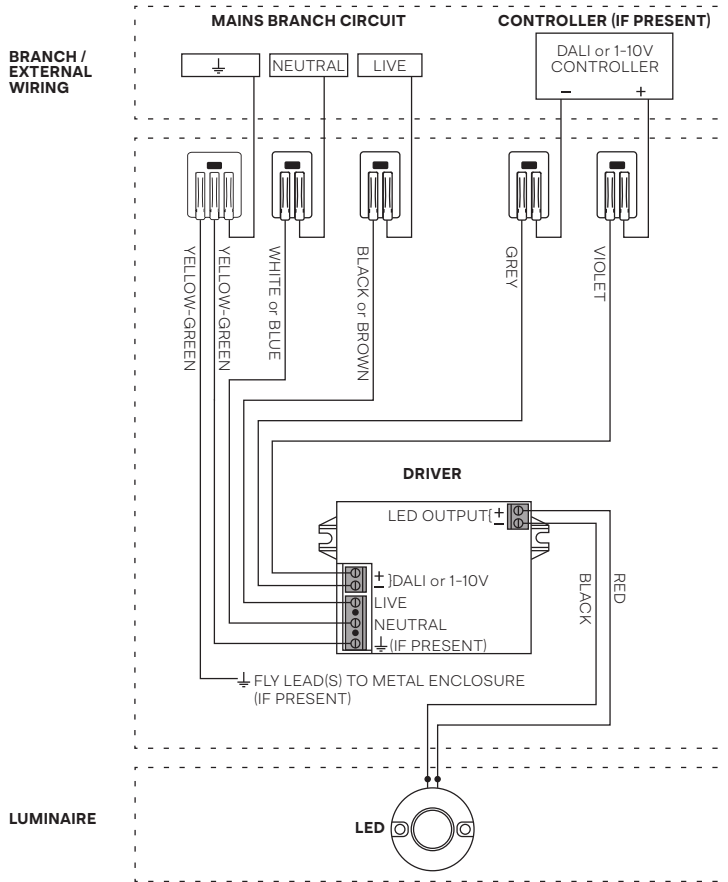

Designed, made & tested in the UK  
1\_INS.WIRING-100-250V.2308  
© Factorylux

